

DSK6XXXHPI

Host Port Interface Daughtercard
for the
Texas Instruments TMS320C6713/6416T
Digital Signal Processing (DSP) Starter Kits

Board revision 1.3a
Firmware revision 1.0.1.0

Educational DSP, LLC
www.educationaldsp.com

- 1 Getting Started 3
 - 1.1 General Precautions 3
 - 1.2 Preparations for Use 3
 - 1.3 Daughtercard Status Indicator 3
 - 1.4 Daughtercard Functional Organization 4
 - 1.5 HPI Operation and Limitations 5
 - 1.6 Using with winDSK6 4.0 5
- 2 Host Services 6
- 3 DSP Services..... 7

1 Getting Started

The DSK6XXXHPI daughtercard supports the TMS320C6713 and TMS320C6416T DSKs.

1.1 *General Precautions*

Proper electrostatic discharge (ESD) precautions should be used at all times when handling the daughtercard. Failure to do so may result in damage to the circuitry. Do not install or remove the daughtercard except when the DSK is deenergized.

This daughtercard is intended only for use in an educational laboratory environment only. It can radiate radio frequency energy and has not been tested for compliance with FCC regulations. Operation of this equipment in other environments may cause harmful interference with other electronic systems.

1.2 *Preparations for Use*

1. Install the provided 2-pin male header at JP2 on the DSK. This will supply 3.3V to power the daughtercard.
2. Install the daughtercard so that it mates to J1 on the DSK. The header installed at JP2 on the DSK will also mate with the connector at JP1 on the daughtercard. Secure the daughtercard to the DSK using the standoffs and screws provided. The rubber bumpers on the bottom of the DSK may need to be moved to expose the holes for attaching the standoffs.
3. For the 6713 DSK, set SW3-3 on the DSK to ON. For the 6416T DSK, set SW3-2 and SW3-3 on the DSK to ON. This will cause the DSP to boot from the host port interface (HPI).
4. In order to use the USB interface, you must install the CP-210x drivers. These are included in the winDSK6 installer.

1.3 *Daughtercard Status Indicator*

The LED on the daughtercard is used to indicate the daughtercard status. There are 3 conditions that may be indicated;

Single-blink - Operating in host services mode, allowing a PC host to download programs and read/write the DSK memory space. Host services mode is entered on reset.

Double-blink – Operating in DSP services mode, where the DSP has control over the daughtercard resources. Return to host services mode by pressing the daughtercard reset button or power cycling the daughtercard.

Continuous ON – Indicates that the HPI port on the DSP is stuck in a busy state. This is normally caused by the DSP keeping its internal peripheral buses so busy that the HPI port cannot gain access. To prevent this, do not have DSP code loops that continuously access a peripheral or the EMIF.

1.4 Daughtercard Functional Organization

The daughtercard is organized as shown in the below figure. There are three ways to communicate with the daughtercard; serial, parallel, or USB.

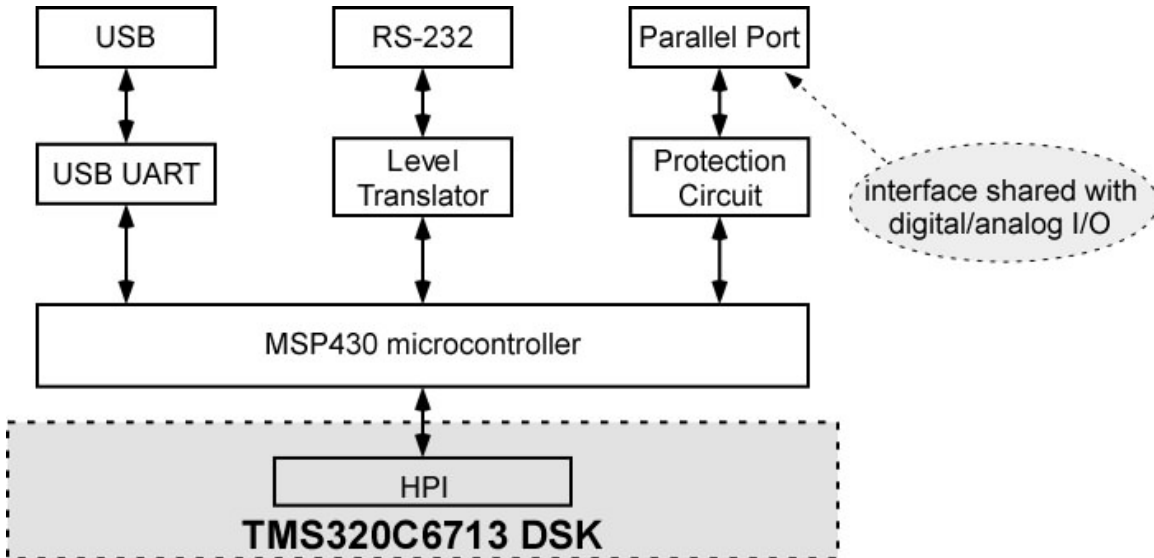

The daughtercard can provide up to 16 digital I/O pins, of which 8 can be used as analog inputs instead. The details of using these pins are discussed the *Host Services* section later in this document. The electrical structure of an I/O pin is shown below. Each pin has a 100k Ω pull-up resistor and 180 Ω series resistor. The pull-up resistor ensures that a valid logic level is present on the microprocessor input pin when nothing is driving the pin. The series resistor has two functions; first, in combination with the diodes it provides some immunity to electrostatic discharge hazards, and second, it provides the pin with limited tolerance to 5V logic signals. The external diode is required due to the very low current rating of the MSP430 input protection diodes (2mA). In general, the input applied to the pin should not be outside the range 0V to 3.3V.

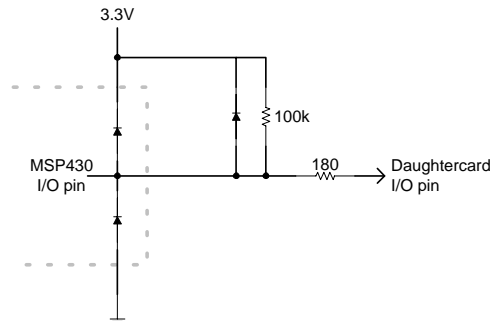

The I/O pins can sink or source approximately 10mA maximum, with the actual current determined by the pin impedance, the series resistor, and the load resistance. An LED can be directly connected between an I/O pin and 3.3V or ground without exceeded the MSP430 current limits.

1.5 *HPI Operation and Limitations*

The HPI port has several important issues to be aware of when using the HPI daughtercard.

- By design, the HPI port can only transfer 32-bit words, so it is not possible to access smaller data words. Therefore, all variables that are going to be read or modified through the HPI port must be 32-bits or larger.
- Any programs loaded through the HPI port must be built with the “run-time auto-initialization” option. The load-time initialization option will not work; since the loader will not be able initialize anything smaller than 32-bits. This is the default setting for the CCS C compiler, so it should not present a problem in most situations.
- All HPI port memory accesses are required to be aligned on 4-byte boundaries (i.e. addresses where the two least-significant bits (LSb) are 0). The HPI address register enforces this by forcing its two LSb to 0. The C67XX architecture requires that all word accesses be on 4-byte boundaries, so non-aligned variables will not occur. On the C64XX architecture, non-aligned words are supported with special intrinsic functions, however, they will still not be accessible through the HPI port.

1.6 *Using the daughtercard with winDSK6*

To run winDSK6 with a TMS320C6713 DSK, you must have winDSK6 version 4.0.0.0 or later, and have the HPI daughtercard attached to the DSK. To run winDSK6 with a TMS320C6416T DSK, you must have winDSK6 version 4.0.1.0 or later, and have the HPI daughtercard attached to the DSK. winDSK6 can interface with the daughtercard using either the serial, parallel, or USB interfaces on the daughtercard.

The daughtercard must be in Host Services mode to run winDSK6. The daughtercard enters Host Services mode upon pressing the daughtercard’s reset switch or by cycling power to the DSK. The Host Services mode is indicated by a slow, uniform flash rate on the daughtercard LED.

1.6.1 **Serial Port Interface**

On the winDSK6 main dialog, set **DSP Type** to **TMS320C6713_COM** or **TMS320C6416T_COM**, and set **Serial/USB** to the desired serial port (**COMx:**) and **RS-232**.

1.6.2 **Parallel Port Interface**

To use the parallel port interface, you must install the Scientific Software parallel port drivers on the computer first.

On the winDSK6 main dialog, set **DSP Type** to **TMS320C6713_LPT** or **TMS320C6416T_LPT**, and set **Parallel** to the desired parallel port (**LPTx:**)

and set the parallel port mode to either **SPP-Nibble** or **SPP** as supported by your computer (**SPP-Nibble** is the slower mode, but is universally supported). The EPP modes are not supported by the daughtercard; if one is selected, the port will be configured to SPP mode.

1.6.3 USB Interface

To use the USB interface, you must install the CP-2101 drivers on the computer first. See appendix A for information on installing the driver.

On the winDSK6 main dialog, set **DSP Type** to **TMS320C6713_COM** or **TMS320C6416T_COM**, and set **Serial/USB** to the desired serial port (**COMx:**) and **USB2**. The COM port selected should be the virtual port that is associated with the CP-2101 driver.

2 Host Services

The host services package is intended to permit the ready development of applications that download and execute programs on the TMS320C6713/TMS320C6416T DSKs, and then control the DSK operation by reading and writing DSP memory.

The host services software has been developed as a dynamic link library (DLL) that is easily linked into the user's application. The software interface is accessed through a small number function calls. Information on the host services functions is available in a separate document.

The daughtercard enters Host Services mode upon reset or power cycling. This mode is indicated by a slow, uniform flash rate on the daughtercard LED.

A sample application is available that demonstrates the use of the host services to control a DSK application. The source code for the host application and the DSK application is contained in the sample application.

3 DSP Services

The DSP Services provide an interface between the TMS320C6713/TMS320C6416T DSKs and a DSK6713HPI daughtercard. The interface allows a DSP application to use the digital I/O, analog inputs, and communications resources on the daughtercard. The parallel port interface is not available when using DSP Services, as these pins are used for digital I/O and analog inputs.

The daughtercard enters DSP Services mode only when the *StartHpiServices* function is called by the software running on the DSK. This mode is indicated by a faster double-blink flash pattern on the daughtercard LED. To return the daughtercard to the Host Services mode, the daughtercard must be reset or power cycled.

The digital I/O consists of 16 pins; the direction of the pins can be set individually. The digital I/O is updated at a 1.0 kHz rate. The digital I/O pins are available at the parallel port connector, as listed in Table 1 below, and accept 3.3V logic levels.

There are 8 analog inputs, with an input range of 0-2.5V and 12-bit resolution. The analog inputs are sampled and updated at a 1.0 kHz rate. When an analog input is enabled, that pin is no longer available for digital I/O.

The serial port interface can be used for RS-232 communications with 8 data, no parity, 1 stop bit, and no flow control. The baud rate can be set to 1200-115200 baud, as listed in the file *hpi_services.h*. The baud rate is set to 115200 baud by default. Buffers on the daughtercard and DSK are used to maximize throughput. The daughtercard checks and updates the DSK data buffers at a 1.0 kHz rate.

The USB interface can also be used for communications. The USB driver makes the USB interface appear to be a COM port on the host computer. On the host, the COM port should be configured to 921600 baud, 8 data, no parity, 1 stop bit, and no flow control. Buffers on the daughtercard and DSK are used to maximize throughput. The daughtercard checks and updates the DSK data buffers at a 1.0 kHz rate.

If your program using the DSP Services is being loaded/run with Code Composer Studio (CCS), please observe the following sequence to ensure the DSP's HPI port is properly configured.

1. Download the program using CCS, but do not run.
2. Press and release the reset button on the DSK6713HPI daughtercard.
3. Run the program from CCS.

If you are using the HPI daughtercard to load the program (i.e. using winDSK6 or C6X_Control to load the program), you do not have to worry about this issue.

The individual DSP Service functions are described in detail in a separate document. A number of sample applications are also available.

Table 1: Input/Output Bit Assignments

Bit	Parallel Port Connector J4		MSP430F148 Port
	Description	Pin	
D0 *	D0	2	P6.0
D1 *	D1	3	P6.1
D2 *	D2	4	P6.2
D3 *	D3	5	P6.3
D4 *	D4	6	P6.4
D5 *	D5	7	P6.5
D6 *	D6	8	P6.6
D7 *	D7	9	P6.7
D8	ERR	15	P1.0
D9	SEL	13	P1.1
D10	PAPER	12	P1.2
D11	ACK	10	P1.3
D12	BUSY	11	P1.4
D13	INIT	16	P1.5
D14	ALF	14	P1.6
D15	STRB	1	P1.7

* D7:0 are also used as analog inputs

** Ground is available at J4 pins 18-25